

HomeCare® Range Terms and Conditions

In your world everything should be clear



Contents

1. Introduction to your Terms and Conditions	1	10. Landlord Services	8
2. Changes to your Terms and Conditions	1	10.1 Landlords Gas Appliance Safety Inspection	8
3. What we can look after Diagram	2	10.2 Landlords Electrical Inspection	8
4. Definitions	2	11. Care Agreements	9
5. General Conditions that apply to all Agreements	2	11.2 Boiler and Controls Care™	9
6. General Conditions – Cancellation	4	11.3 Central Heating Care™	9
7. General Exclusions that apply to all Agreements	4	11.4 Gas Appliance Care™	9
8. Cover Agreements	5	11.5 Gas Appliance Check™	9
8.2 Boiler and Controls Breakdown Cover™/ Central Heating Breakdown Cover™	5	11.7 Plumbing Care™	9
8.3 Boiler and Controls Cover™/ Central Heating Cover™	5	11.9 Plumbing and Drains Care™	10
8.5 Gas Appliance Cover™	6	11.11 Home Electrical Care™	10
8.8 Plumbing Cover™	6	11.13 Kitchen Appliance Care™	10
8.10 Plumbing and Drains Cover™	7	11.14 Complaints	11
8.14 Water Supply Pipe Cover™	7	12. Using Personal Information	11
8.16 Home Electrical Cover™	7	13. Other Products and Services	12
8.18 Kitchen Appliance Cover™	8	13.1 PowerFlush™	12
8.20 Complaints	8	13.2 System filters and scale reducers	12
9. TimeChoice™ for Cover/Care Agreements	8	13.3 Condensate pipe kits	12
		14. Frequently asked questions	12

Please click on the section titles above, or alternatively or use the interactive buttons at the bottom of the page to navigate through the HomeCare® Range product Terms and Conditions.

1. Introduction to your Terms and Conditions

We have designed these products to provide a safe, high-quality service to 'repair' or 'maintain and repair' the elements included in your Agreement. It is important you read these terms and conditions together with your Statement confirming the products you hold carefully, as these form the basis of your agreement with us. If anything is not correct on your Statement, or if you have any questions, please call us on **0800 365 100**.

Customers can choose to hold our products as part of a package (HomeCare 100-400™) or individually as separate Agreements. See your Statement for confirmation of the products you hold.

About the Package you've chosen	Boiler and controls	Central heating	Plumbing and Drains (including with or without water supply pipe)	Home Electrics
HomeCare 100™	✓			
HomeCare 200™	✓	✓		
HomeCare 300™	✓	✓	✓	
HomeCare 400™	✓	✓	✓	✓

2. Changes to your Terms and Conditions

Please read the material changes to our terms and conditions below.

- All Care Agreements have been changed from rolling monthly contracts to renewable annual contracts to align with our Cover Agreements. We have inserted a definition of 'Period of Agreement' making it clear that both Cover Agreements and Care Agreements are annual contracts.
- The cancellation charge section has been changed to give clarity to the charges you may be required to pay for cancelling your Agreement where you have had a repair. We have also simplified the instances in which we may cancel your Agreement.
- We have clarified that for Plumbing Cover™/Care™ and Plumbing and Drains Cover™/Care™ we do not repair temporarily frozen pipes which have not resulted in confirmed damage.
- Additional benefits have been added to Home Electrical Cover™/Care™. In accordance with the terms and conditions, these benefits include repairs to outside security and doorway lighting, rodent damage to wiring and repairs to electric doorbells. Home Electrical Care™ also includes repairs to electric vehicle charging units and solar photovoltaic panels which have been installed by us.

- We have added a £48 charge in respect of an annual service we have provided, and a £24 charge in respect of Landlord's Gas Appliance Safety Inspection we have carried out to the section on the charges we will impose should you cancel your agreement part way through the agreement period.
- The cancellation charge section has been changed to give clarity on how often you are able to purchase a different agreement with us and still be eligible for any benefits that may come with a new agreement.

Terms and Conditions for your Agreement

3. What we can look after

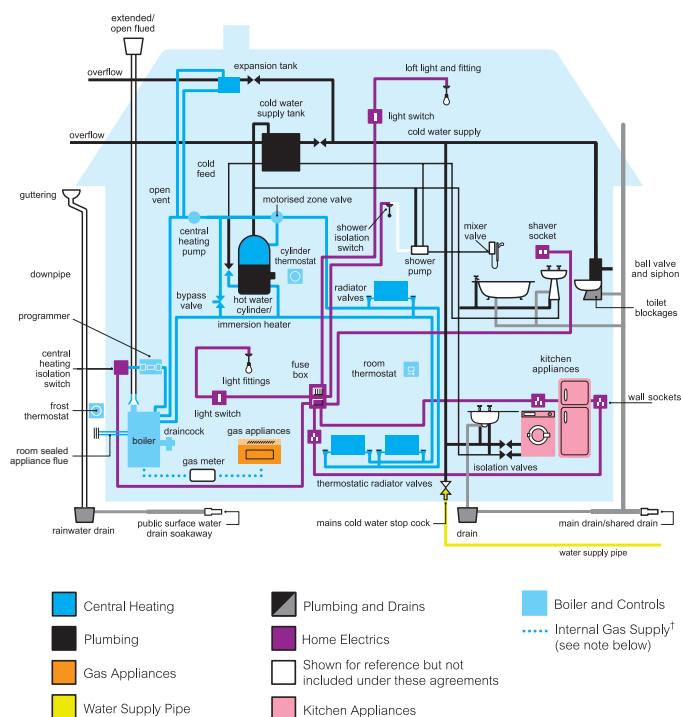

4. Definitions used in your Terms and Conditions

Wherever the following words and phrases appear, they will have the following meaning:

Agreement: means each agreement you have with us, whether a Care Agreement or Cover Agreement.

Annual Service: for Agreements that include an Annual Service, means a visit we undertake in each Period of Agreement to check the elements included in your Agreement are safe and in good working order. Further details are contained in the section headed 'General Conditions'.

Care Agreement: means our non-insurance agreements in the section headed 'Care Agreements'.

Cover Agreement: means our insurance agreements in the section headed 'Cover Agreements'.

Domestic Purposes: means at least half the rooms at the Home must be used for normal living purposes and not more than half the rooms are used in any connection with a business, trade or profession.

Excess: means an amount you have chosen to pay (as shown on your Statement) as the first part of each claim under your Cover Agreement. Further details are contained in the section headed 'General Conditions'.

First Service: for Agreements that require a First Service, means a visit we undertake towards the beginning of your first Period of Agreement to confirm we can accept the elements included under your Agreement. Further details are contained in the section headed 'General Conditions'.

Fixed Fee: means an amount you have chosen to pay (as shown on your Statement) each time we complete a repair under your Care Agreement. Further details are contained in the section headed 'General Conditions'.

Home: means your place of residence or a home owned by you that is a private domestic dwelling including any covered garage connected to your home.

Maintenance Inspection: for Agreements that include a Maintenance Inspection means a visit we undertake to check the elements included in your Agreement are safe and in good working order. Further details are contained in the section headed 'General Conditions'.

Period of Agreement: means the length of your Agreement shown on your Statement. Your Agreement begins on the date your application is accepted and normally runs for 12 months. If you add additional products to an existing Agreement, the Period of Agreement for any new products may be less than 12 months so that we can align your products so that they all renew at the same time each year.

Our/us/we: means British Gas Services Limited which is the administrator for and on behalf of British Gas Insurance Limited for our Cover Agreements and the provider of services for our Care Agreements.

Powerflush™: means a product available for purchase that is designed to remove sludge and other waste from central heating systems. Further details are contained in the section headed 'Other Products and Services'.

Statement: means a written statement you receive from us that confirms the products you hold, the price for the products and any Excess/Fixed Fee you have agreed to pay for each repair.

System: includes your expansion tank, pipework, cylinder and radiators.

You or your: means the person named on your Statement, together with the members of your household who normally reside with you.

5. General Conditions that apply to All Agreements

5.1 Periods of Agreement

The duration of your Agreement is shown on your Statement and will commence on the date your application was accepted.

Note that for Boiler and Controls Breakdown Cover™ and/or Central Heating Breakdown Cover™ breakdowns in the first 14 days of your first year are not included.

5.2 Price and Price Changes

Your Agreement price is set out in your Statement and will not change during your Period of Agreement unless the Government introduces a change in the relevant tax rate. We will always write to you to tell you about any change to your price and Direct Debit instalments.

5.3 Payments

If you choose to pay by Direct Debit you can pay either annually or monthly. If you choose to pay by cheque, credit card or debit card (all paid annually) we may charge you a small administration fee for processing your payment. All of our charges are inclusive of relevant taxes at the prevailing rate.

5.4 Renewals

Prior to the end of your Period of Agreement, we will write to you to tell you about any changes to what is included in your Agreement or any changes to your prices for the next year. Unless you tell us when we write to you that you do not wish to renew, we will automatically renew your Agreement for another year.

5.5 Excess/Fixed Fee options

You can choose to pay an Excess (for Cover Agreements) or a Fixed Fee (for Care Agreements). The amount of the Excess or Fixed Fee you agree to pay (as shown on your Statement) is payable for every completed repair including related faults (a further Excess/Fixed Fee will apply for repair of unrelated faults). We will ask for pre-authorization of any Excess or Fixed Fee by credit or debit card at the same time that we book your appointment. Payment will not be taken until we have completed your repair.

We guarantee all of our repair work for a period of 12 months (see section 5.15). If you request further visits to remedy breakdowns, even within 12 months of a previous visit, we may still require pre-authorization for the payment of any Excess or Fixed Fee. Our engineer will determine whether the fault is related to a previous breakdown visit in the last 12 months and therefore whether any Excess/Fixed Fee is payable.

5.6 Domestic use

Agreements are only available for appliances and systems used inside your Home for Domestic Purposes. If you own a domestic property which you let out, you can hold our Agreements for your tenanted property.

5.7 Service coverage

There are a few remote areas of Great Britain where we do not currently provide Agreements. If this affects you, we will tell you when you apply.

5.8 Our responsibilities

We will meet our responsibilities under your Agreement(s) within a reasonable time unless it is impossible because of circumstances outside our control. If we are unable to meet our responsibilities, we will notify you as soon as possible confirming the reasons why we are unable to meet our responsibilities and provide you with an alternative time when we expect we can satisfy our obligations to you.

5.9 Boilers

If your Agreement includes repairs to boilers:

- Whether or not we installed your boiler, if we agree that your boiler is less than seven years old we will provide a suitable new replacement boiler approved by us if it is not possible to repair yours because, for example, spare parts are not available, or we decide that it would cost more to repair the boiler than to replace it.
- If we installed your boiler and we agree that your boiler is seven years old or more but is less than 10 years old plus you have had a continuous Boiler and Controls Cover™/Care™ or Central Heating Cover™/Care™ Agreement for the life of the boiler, we will provide a suitable new replacement boiler approved by us if it is not possible to repair yours because, for example, spare parts are not available, or we decided that it would cost more to repair the boiler than to replace it.

Outside of these specific circumstances or any other specific circumstances specified in your Agreement, you are not entitled to a replacement boiler.

5.10 Maintenance Inspection

If you are a boiler and controls/central heating and plumbing and drains customer entitled to a Maintenance Inspection on your plumbing it will be conducted at the same time as any Annual Service of your central heating system (in which case there will be no additional separate Maintenance Inspection once in every two years).

For customers entitled to a Maintenance Inspection (but not an Annual Service) your Maintenance Inspection will be dependent on you contacting us to arrange it and the scheduling will be dependent on our workload.

5.11 Gaining access to your property and arranging appointments

Our engineers need to be accompanied in your property at all times by someone aged over 18 years. It is your responsibility to allow us access to your property. If we cannot gain access, we will be unable to carry out the necessary work and you will need to arrange another appointment.

If you do not arrange an appointment or we cannot gain access, your Agreement will continue even though we have been unable to carry out the work. If, after several attempts, you have not made an appointment or we still cannot gain access, we may write to you to let you know we have cancelled your Agreement.

5.12 Safety advice

We may advise you that permanent repairs or improvements are needed to help ensure your appliance or system works safely (for example, to comply with gas safety regulations, such as upgrading your ventilation to meet current standards). If you do not follow our advice, it may mean that we are unable to fulfil all of our obligations to you under your Agreement. In this case, your Agreement will continue to run unless you tell us you would like to cancel or if we cancel (see 'Your Cancellation Rights' and 'Our Cancellation Rights').

5.13 Spare parts

If your engineer does not carry the spare parts needed on the day of your appointment, we use a central stock of 30,000 parts which means we can normally get hold of most items the following working day. Otherwise, we will do all we reasonably can to find and install parts from our approved suppliers. We may use other approved parts or parts that have been reconditioned by the original manufacturer.

5.14 Labour

One of our engineers will usually carry out the work. In some cases we may authorise a suitably qualified contractor to carry out the work. All of our contractors carry identity cards.

5.15 Guarantees

We guarantee to make good any faulty parts and/or defective workmanship for a period of 12 months from the date we completed your repair. The rights in relation to any guarantee we give you are in addition to, and do not affect your legal rights under the Sales of Goods Act 1979 and Supply of Goods and Services Act 1982. You can get advice about your rights from a Citizens Advice Bureau or Trading Standards Department.

5.16 Moving home

You will need to notify us as soon as possible about any change of address as you may not be covered in the event of a claim at your new property. Once we receive new address details from you for your new Home we will transfer your Agreement to this new address (unless you tell us you do not want to continue with your Agreement) and arrange a First Service for your new Home (see 5.18).

5.17 Governing law

The terms and conditions for all Agreements are written in English and all correspondence entered into shall be in English. Your Agreement is governed by the laws of England and Wales where your home is located in England or Wales and by the laws of Scotland where your home is located in Scotland.

5.18 First Service

If your Agreement includes a First Service, we will arrange to inspect your boiler and controls/gas central heating system/gas appliance (depending on what is included in your Agreement), to help ensure we can include them in your Agreement and that they are safe and in good working order.

We will normally carry out your First Service within 42 days of your first Agreement, although it may be later if there is a lot of demand for our services especially in colder weather.

Our engineer will fill in a service/breakdown checklist to show you what has been inspected. If your First Service reveals a problem (such as boilers for which we know we cannot obtain parts, or systems that are installed unsafely or are inaccessible) we may:

- Tell you what work is needed and what it will cost to do that work;
- Offer you a different product which will not include the part(s) of your system causing the problem which we are unable to include in your Agreement; or
- Cancel your Agreement and refund any money you have paid.

We will not carry out a First Service if we have already carried out a First Service or Annual Service at the same property in the previous 12 months, irrespective of any change of ownership.

5.19 Annual Service

If your Agreement includes an Annual Service, we will arrange to visit your Home in the second and subsequent years of your Agreement to inspect your boiler and controls/gas central heating system/gas appliance (depending on what is included in your Agreement) to help ensure that they are safe and in good working order.

We will normally complete your Annual Service around twelve months from the date of your last Annual Service. In periods of high demand for our services (such as cold weather), we prioritise breakdowns and may need to rearrange your Annual Service visit. If you have a breakdown in the four months before your Annual Service is due, we may complete it at the same time we visit to repair the breakdown to your system or appliance. We will not normally carry out an Annual Service if we have already carried out a First Service or Annual Service at the same property in the previous 12 months, irrespective of any change of ownership.

6. General Conditions – Cancellation

6.1 Your Cancellation Rights

You may cancel any Agreement you have with us at any time provided you notify us by calling **0800 0727 513** or by writing to us at HomeCare® Membership Office, Murdoch House, Bothwell Road, Uddingston G71 7UD. Cancelling your Direct Debit without notifying us will not cancel your Agreement with us.

If you cancel within the first 14 days (starting from the day after you receive written confirmation of your Agreement with us), we will give you a full refund of any money you have paid, unless we have carried out a repair in which case cancellation charges may apply (see section 6.2).

If you cancel after the first 14 days (starting from the day after you receive written confirmation of your Agreement with us), we will give you a full refund of any money you have paid for the time left to run in your current Period of Agreement after the point of cancellation unless we have carried out a repair in which case cancellation charges may apply (see section 6.2).

If you cancel a current agreement in order to purchase an equivalent product supplied through British Gas Insurance or any associated British Gas Insurance partnership twice or more within a 3 year period, you will not be eligible for acquisition benefits such as an introductory pricing offer.

6.2 Cancellation Charges

If you cancel any Agreement you have with us part way through your Period of that Agreement and you have work completed in respect to that Agreement, we may charge you a contribution towards the costs we have incurred but not yet recovered.

Your cancellation charge will be the total of the amounts specified in the table below:

- Less any Excess and/or Fixed Fee payments you have made for each repair;
- Less all the scheduled payments you have made in your Period of Agreement; and
- The total of any cancellation charges will not exceed your annual price as specified on your Statement.

Type of work completed	Charge for each piece of work completed
Boiler/Central Heating repairs	£115
All other completed repairs	£50
Annual Service	£48
Landlords Gas Appliance Safety Inspection (LGASI)	£24

6.3 Our Cancellation rights

We may cancel your Agreement in the following circumstances:

- If you have given us false information;
- If you do not make an agreed payment;
- We find something wrong at a First Service;
- Where there are health and safety issues;
- Your appliance or system is not on our approved list;
- You do not provide us with access to your property where required;
- We are not reasonably able to find parts for your appliance or system; and
- Permanent repairs or improvements we tell you are required are not completed.

If we cancel at the First Service, we will give you a full refund of any money you have paid. If we cancel your Agreement at any time after your First Service, we will refund any money you have paid for the time left to run in your current Period of Agreement after the point of cancellation.

7. General Exclusions that apply to all agreements

7.1 Design or existing faults

We will not be responsible for the cost of repairs or gaining access to make repairs where there are design faults (unless we are responsible for the design faults), faults which existed before you entered into your Agreement with us or faults which we could not, using reasonable care and skill, identify on our First Service of your system or appliance. For example, pipes buried under concrete floors that have been installed incorrectly or without wrapping or movement protection.

7.2 Accidental damage/third-party damage/damage from intentional risk taking

Except where accidental damage caused by you is specifically stated as being included under your Agreement, the cost of repairs relating to damage caused by you is excluded. Where work is undertaken on your system or appliance by a third party, whether or not following our advice, which results in damage to that or another part of your system as a result of poor workmanship, the repair of any such damage will be excluded from your Agreement.

7.3 All other loss and damage

Unless we cause it, we will not be responsible for any loss or damage to property as a result of your appliance or system breaking/ failing, including any cleaning needed or damage to fixtures/furniture (for example, damage caused by water leaks).

7.4 Making good

We will fill in any holes and leave the surface level where access has to be made to your system or appliance, in order to carry out a repair, but we will not replace the original surface or construction (e.g. redecoration).

7.5 Risks normally insured under household or other insurances

Except and only to the extent specifically stated as being included under your Agreement, we will not include the repairing of faults or damage or replacement of appliances or systems caused by freezing weather conditions, subsidence, structural repairs, accident, fire, lightning, explosion, flood or storm. You should check your household insurance to make sure you have enough cover for these risks.

If anything specifically stated as being included under your Agreement is also included under any other insurance or maintenance contract you hold, the repair will be the responsibility of the provider of your other insurance or maintenance contract. In the event of joint responsibility with your other provider, we will only ever be responsible for our fair share and to the extent of our obligations under your Agreement.

7.6 Approved equipment

For certain items we maintain an approved list. We only undertake work on gas/electric appliances, central heating system controls, energy-management systems and plastic pipes which are on our approved list.

7.7 Third-party rights

Nobody other than you will be able to benefit from your Agreement, which cannot be passed to someone else without our written consent.

7.8 Other Exclusions

We will not include the following:

- Any costs over £1,000 (inc. VAT) to gain access to your system, built in appliances, buried pipe work or wires to make a repair and then make good (see section 7.4). We do not include the cost of getting to your appliance or system where it is inaccessible due to a design fault. Separate exclusions apply to Drains and Water Supply Pipe repairs under sections 8.12 and 8.16.
- Replacing appliances, bathroom fixtures, showers and sanitary ware except as are specifically stated as being included under your Agreement.
- Improvements including work that is needed to bring your appliance/system up to current standards/legislative requirements. You may need to have improvements carried out before we are able to complete other repairs to your appliance/system.
- Upgrades which you may want to have carried out to improve your appliance/system.
- Replacing or repairing parts that do not affect how the appliance/system works or decorative or specialist parts.
- Resetting controls (for example, thermostats and programmers following changes due to winter or summer).
- Removing asbestos associated with repairing the appliance/system. When you have had any asbestos removed, you must give us a clean-air certificate before we will do any further work at your property. By law, the person who removes the asbestos must give you a clean-air certificate.

- Cash alternatives for service, maintenance or repair.
- Repairing or replacing any lead, steel or central heating iron pipes (other than where the gas-supply pipe from meter to appliance is specified stated as being included under your Agreement).
- The cost of repairing damage or breakdowns caused by changes to, or problems with, the gas, electricity or water services.
- Commencing and/or continuing services where we reasonably consider that there is a Health and Safety risk including: the presence of; hazardous materials; infestations; or harassment of our personnel including verbal or physical abuse. We will not recommence work until the Health and Safety risk has been rectified to our satisfaction.

8. Cover Agreements

8.1 The Insurance products

All Cover Agreements are insurance policies which are underwritten by British Gas Insurance Limited. British Gas Insurance Limited is authorised and regulated by the Financial Services Authority. British Gas Services Limited administers the policies, manages all claims and holds premium, refunds and any claims monies as agent for and on behalf of British Gas Insurance Limited.

8.2 Boiler and Controls Breakdown Cover™/ Central Heating Breakdown Cover™

Boiler and Controls Breakdown Cover™ (and £50 and £99 Excess versions) and Central Heating Breakdown Cover™ (and £50 and £99 Excess versions) are products designed to meet the demands and needs of householders who want protection in place in the event of various problems with their boiler and controls/central heating on a repair only basis.

Note that for Boiler and Controls Breakdown Cover™ and/or Central Heating Breakdown Cover™, breakdowns in the first 14 days of your first Period of Agreement are not included.

The following are included in your Agreement:

- For Boiler and Controls Breakdown Cover™, repairs in the event of a breakdown of a single gas boiler and controls (shown in light blue on the diagram on page 2) in your Home.
- For Central Heating Breakdown Cover™, repairs in the event of a breakdown of a single gas boiler and controls (shown in light blue on the diagram on page 2) and a single wet (using water) or warm air heating system (shown in blue on the diagram on page 2) in your Home. Warm air vents are covered for warm air units only.

- Parts and labour – as long as all the essential working parts are available and the appliance is on our approved list.
- Boiler replacement under the circumstances and in accordance with the terms of the 'General Conditions' (see section 6).
- If you have a central heating, plumbing and drains and home electrics product we also include in your Agreement repairs to all gas-supply pipework inside your Home, between your meter and any appliances (shown as blue dots on the diagram on page 2).
- Costs up to £1,000 (including VAT) we would incur to get access to your system/appliance in order to make a repair, (for example, pipes buried in walls or 'built-in' appliances) and making good. Making good damage caused by gaining necessary access means filling or plastering to make level but excludes any redecoration which will be your responsibility. We do not include the cost of getting to your appliance where your system is inaccessible due to a design fault.

The Exclusions below and the General Conditions and Exclusions apply (see sections 5 to 7).

8.3 Boiler and Controls Cover™/Central Heating Cover™

Boiler and Controls Cover™ (and £50 and £99 Excess versions) and Central Heating Cover™ (and £50 and £99 Excess versions) are products designed to meet the demands and needs of householders who want protection in place in the event of various problems with their boiler and controls/central heating on a repair and maintenance basis (including an Annual Service).

All of the benefits of Boiler and Controls Breakdown Cover™/Central Heating Breakdown Cover™ plus:

- First Service in your first Period of Agreement and an Annual Service in subsequent Periods of Agreement for your boiler (where you have Boiler and Controls Cover™) and central heating system (where you have Central Heating Cover™).
- Accidental damage – repairs to your boiler and controls/central heating system in the event of accidental damage by you which affects its functioning.
- Boiler replacement under the circumstances and in accordance with the terms of the 'General Conditions' (see section 6). In addition (and provided you granted us access each time we sought to undertake your First Service and Annual Service), boiler replacement irrespective of its age, if there is damage to the boiler (or gas appliance) caused by a fire or explosion of the boiler (or gas appliance) itself, which leaves it irreparable. We will supply and fit any replacement boiler (or gas appliance). In addition, if in our view, your Home has become uninhabitable and remains so overnight as a result of the fire or explosion of the appliance, we will provide alternative accommodation for three nights and transport costs to such accommodation up to a combined maximum of £150 per night including VAT.

- Where we have installed it, your Agreement includes repairs for any electric system and maintenance and repairs for solar thermal system.

The Exclusions below and the General Conditions and General Exclusions apply (see sections 5 to 7).

8.4 Boiler and Controls and Central Heating Exclusions

The following are not included in your Agreement:

- Removing sludge or hard-water scale from your system or appliance.
- Repairing damage caused by scale, sludge or other debris if we have told you on a previous visit that permanent repairs, improvements or a PowerFlush™ (or a similar cleaning procedure) are needed to help ensure your appliance/system works properly.
- Repairing or replacing appliance flues, or flue terminals that are not a part of the flue system, other than room sealed appliance flues (up to 1m in length).
- Servicing and maintenance of electric boilers.
- Repairing or replacing parts of your central heating system and controls that are specifically designed for piped or electric underfloor heating (other than warm-air systems).

8.5 Gas Appliance Cover™

Gas Appliance Cover™ (and £50 Excess version) is a product designed to meet the demands and needs of householders who want protection in place in the event of various problems with their gas appliances.

The following are included in your Agreement:

- Service and repairs of gas appliances e.g. fires, water heaters, wall heaters and cookers in your Home (shown in orange on the diagram on page 2). The appliances included under your Agreement will be set out in your Statement.
- Parts and labour – as long as all the essential working parts are available and we have approved your appliance.
- Annual Service of your appliance.
- Accidental damage – repairs to your gas appliance(s) in the event of accidental damage by you which affects its functioning.
- Appliance replacement irrespective of its age (provided you granted us access each time we sought to undertake your Annual Service), if there is damage to the gas appliance caused by a malfunction resulting in fire or explosion of the gas appliance itself, which leaves it irreparable. In this event we will replace your gas appliance with one of similar make and functionality. If in our view, your Home has become uninhabitable and remains so overnight,

as a result of the fire or explosion of the appliance, we will provide alternative accommodation for three nights and transport costs to such accommodation up to a combined maximum of £150 per night including VAT.

- Costs up to £1,000 (including VAT) we would incur to get access to your system/appliance in order to make a repair, (for example, pipes buried in walls or 'built-in' appliances) and making good. Making good damage caused by gaining necessary access means filling or plastering to make level but excludes any redecoration which will be your responsibility. We do not include the cost of getting to your appliance where your system is inaccessible due to a design fault.

The Exclusions below and the General Conditions and General Exclusions apply (see sections 5 to 7).

8.6 Gas Appliance Exclusions

The following are not included in your Agreement:

- Repairing or replacing appliance flues other than room sealed appliance flues (up to 1m in length). This does not include flue terminals that are not a part of the flue system.

8.7 Plumbing and Drains

Plumbing Cover™ (and £50 Excess version) and Plumbing and Drains Cover™ (and £50 Excess version) are products designed to meet the demands and needs of householders who want protection in place in the event of various problems with their internal plumbing or their internal and external drains.

8.8 Plumbing Cover™

The following are included in your Agreement:

- Repairs or replacement inside your Home and to fixed external pipes if supplying water from your Home in the event of leaks or mechanical failure of (shown in black on the diagram on page 2):
 - hot and cold water pipes from the mains stopcock inside your Home leading to your taps and garden taps
 - your cold water storage tank
 - leaking overflow pipes
 - standard ball valves and toilet siphon
 - pipes that burst as a result of cold weather
 - central heating water pipes if there is a water leak
 - radiator valves
 - hot water cylinders and immersion heaters; and
 - washing-machine and dishwasher hot and cold flexible pipes (as long as they are installed to the manufacturer's instructions).

- Parts and labour for fitting standard replacement parts. Standard replacement parts may differ from the original, for example, using a standard flush handle to replace a gold plated flush handle, unless an alternative is provided by you.
- Repairs to taps and replacing standard non ceramic tap washers to repair water leaks and dripping taps (not including replacing taps themselves).
- Repair of accidental damage to hidden internal pipes but only in the specific circumstances where you damage it, through accidentally puncturing it with a nail, screw or similar fastening which results in a water leak.
- Costs up to £1,000 (including VAT) we would incur to get access to your system/appliance in order to make a repair, (for example, pipes buried in walls or 'built-in' appliances) and making good. Making good damage caused by gaining necessary access means filling or plastering to make level but excludes any redecoration which will be your responsibility. We do not include the cost of getting to your appliance where your system is inaccessible due to a design fault.
- If you previously held Plumbing or Plumbing and Drains Care™ and we moved you to Plumbing or Plumbing and Drains Cover™, you are entitled to a Maintenance Inspection at your request to check for water leaks on your internal pipework, valves and hot water cylinder once in every two-year continuous period of your Agreement.

The Exclusions below and the General Conditions and General Exclusions apply (see sections 5 to 7).

8.9 Plumbing Cover™ Exclusions

The following are not included in your Agreement:

- Replacing ceramic discs in taps unless we can replace from the limited van stock range our engineers carry.
- Replacing taps.
- Bath and shower seals/grouting.
- Repairing or replacing the mains cold water stopcock, water softeners, shower pumps and mixer valves, combined overflow and pop up waste mechanism, mechanical pumps, water filters, radiators, swimming pools, decorative garden features, rainwater pipes and guttering, waste disposal units, macerators such as Saniflo, and electrical units for toilets.
- Repair and replacement of lead and steel pipes.
- Temporarily frozen pipes which have not resulted in confirmed damage.

Please see Page 7 for Drains exclusions.

8.10 Plumbing and Drains Cover™

All the benefits and terms of Plumbing Cover™ plus Drains:

8.11 Drains

The following are included in your Agreement:

- Restoring flow by getting to and unblocking or repairing drainage pipes and waste pipes (shown in grey on the diagram on page 2), for example, unblocking sinks, waste and rainwater drains. This applies to pipes within the boundary of your property but only where you have sole responsibility for the pipes (this does not include public or shared drains even if these are within the boundary of your property).
- Parts and labour are included up to £1,000 (including VAT) per claim to access your system and make repairs.

The Exclusions below and the General Conditions and General Exclusions apply (see sections 5 to 7).

8.12 Drains Exclusions

The following are not included in your Agreement:

- Repairing or unblocking drains shared with another property or properties **that are the responsibility of your water company.**
- Repairing or replacing manholes, soakaways, septic tanks, cesspits, treatment plants and their outflow pipes.
- Regularly cleaning your drains and any de-scaling of your drains.
- Repairing or unblocking drains outside the boundary of your property.
- Repairing or unblocking drains which are used for mainly commercial purposes.
- Making access to drain systems points of entry (such as manhole covers) where these have been built over.
- Repairing or replacing any steel or lead pipes.
- Temporarily frozen pipes which have not resulted in confirmed damage.
- Costs over £1,000 (including VAT) per claim.

8.13 Plumbing, Drains and Water Supply Pipe Cover

All the benefits and terms of Plumbing and Drains Cover™ plus Water Supply Pipe Cover™.

8.14 Water Supply Pipe Cover™

Water Supply Pipe Cover™ is a product designed to meet the demands and needs of householders who want protection in place in the event of various problems with their stopcock and water supply pipe.

The following are included in your Agreement:

- Blockage, collapse or leakage of the mains water supply pipe from and including the stopcock in your Home up to where it is connected to the public or shared water supply pipe within the boundary of your property, if you are responsible for this.
- Leaking or seized stopcocks where the stopcock is in your Home, or within the boundary of your property and that you are responsible for.
- Parts and labour are included up to £1,000 (including VAT) per claim to access your system and make repairs.

The Exclusions below and the General Conditions and General Exclusions apply (see sections 5 to 7).

8.15 Water Supply Pipe Cover™ Exclusions

The following are not included in your Agreement:

- Repairing water supply pipes shared with another property or properties **that are the responsibility of your water company.**
- Repairing or replacing manholes, soakaways, septic tanks, cesspits, treatment plants and their outflow pipes.
- Repairing water supply pipes outside the boundary of your property.
- Repairing water supply pipes which are used for mainly commercial purposes.
- Water pipes to or from and in detached outbuildings, fountains, swimming pools, ponds, other decorative garden features, garden taps, treatment plants, rainwater pipes, roofs, guttering or other external property.
- Temporarily frozen pipes which have not resulted in confirmed damage.
- Costs over £1,000 (including VAT) per claim.

8.16 Home Electrical Cover™

Home Electrical Cover™ (and £50 Excess version) is a product designed to meet the demands and needs of householders who want protection in place in the event of various problems with their electrical wiring and fixtures.

The following are included in your Agreement:

- Repairs of electrical wiring and electrical fixtures inside your Home (shown in dark purple on the diagram on page 2) and within outbuildings as long as the outbuildings do not contain their own power supply and the wiring and fixtures have been installed correctly. This covers the fixed electrical wiring system and fuse boxes, light switches, wall sockets, light fixtures, circuit breakers and transformers.
- Parts and labour are included for fitting standard replacement parts, for example, we will replace all fittings with our nearest equivalent standard white plastic, brass or chrome effect fitting unless an alternative is provided by you.
- Outside security/doorway lighting fitted less than 10 metres above ground level.
- Rodent damage to wiring (property must not be unoccupied for a continuous period of 4 weeks or more).
- Repairs to electric door bells (excluding door entry systems), bathroom extractor fans and smoke alarms connected to the wiring of your Home.
- Repair of accidental damage to the electrical wiring inside your Home but only in the specific circumstance where you accidentally damage a hidden electrical cable through puncturing it with a nail, screw or similar fastening and this results in a failure of all or part of your electrical system.
- Repair of accidental damage, if caused by you, to your light switches, light sockets or plug sockets. If a replacement is required, we will fit standard replacement parts unless an alternative is provided by you.
- Costs up to £1,000 (including VAT) we would incur to get access your system/appliance in order to make a repair, (for example, pipes buried in walls or 'built-in' appliances) and making good. Making good damage caused by gaining necessary access means filling or plastering to make level but excludes any redecoration which will be your responsibility. We do not include the cost of getting to your appliance where your system is inaccessible due to a design fault.
- If you previously held Home Electrical Care™ and we moved you to Home Electrical Cover™, you are entitled to a Maintenance Inspection at your request once in every two-year consecutive Periods of Agreement.

The Exclusions below and the General Conditions and General Exclusions apply (see sections 5 to 7).

8.17 Home Electrical Cover™ Exclusions

The following are not included in your Agreement:

- Repairing controls, pumps, detectors, timers and programmers.
- Repairing or replacing the mains supply up to the fuse box.
- Repairing the parts of the power supply between your Home and the outbuildings on your property that are outside of the buildings.
- Repairing or replacing rubber or lead wiring.
- Repair of accidental damage to the main electrical consumer unit or fuse box.

8.18 Kitchen Appliance Cover™

Kitchen Appliance Cover™ (and £50 Excess version) is a product designed to meet the demands and needs of householders who want protection in place in the event of various problems with one or more of their kitchen appliances.

Eligibility for Kitchen Appliance Cover™:

- The appliances must be bought in the UK.
- Types of appliances that can be covered are:
 - automatic and tub washing machines;
 - automatic washer-dryers, spin and tumble dryers and dishwashers;
 - fridges, freezers, fridge-freezers; and
 - cookers, ovens, hobs and microwave ovens (but not cooker hoods and extractors).
- The appliances must be in good working order at the time you enter into the Agreement.

The following are included in your Agreement:

- Maintenance and repairs, including parts and labour, of gas and electrical appliances inside your Home (shown in lilac on the diagram on page 2).
- Appliance replacement – if your appliance is beyond repair, for example, because spare parts are no longer available or it is not economical to repair:
 - if it is under 3 years old at time of breakdown we will contribute 100% to the retail selling price of an appliance of a similar make and functionality in full settlement of your claim.
 - if it is 3 years old or more at time of breakdown we will contribute 30% to the retail selling price of an appliance of a similar make and functionality in full settlement of your claim.

The age of the appliance will be verified or estimated by the Engineer. Please provide a copy of the purchase receipt with date where possible. This is the only proof that will be accepted to dispute the Engineer's determination of the age.

Contributions towards the cost of new appliances are in the form of vouchers from one of our preferred suppliers. We are not responsible for the disconnection or disposal of the old appliance or the installation of the new one.

- If you previously held Kitchen Appliance Care™ and we moved you to Kitchen Appliance Cover™, you are entitled to a Maintenance Inspection at your request of the kitchen appliances included under your Agreement once in every two consecutive Periods of Agreement.

The Exclusions below and the General Conditions and General Exclusions apply (see sections 5 to 7).

8.19 Kitchen Appliance Cover™ Exclusions

The following are not included in your Agreement:

- Pre-existing faults.

8.20 Complaints

We will always aim to do our best, but unfortunately there may be times when things go wrong. If you have a complaint about any part of our service or your products please telephone us on **0800 294 9650** or write to us at:

British Gas Services,
Customer Relations,
PO Box 4395,
Dunstable LU6 9LH

or email us at:
BGS.CustomerRelations@centrica.com

We will try to deal with the matter immediately but if we can't then we will keep you regularly informed about the progress of our investigation. If you are unhappy with our final response – or if we have not been able to complete our investigation within 8 weeks of our receiving your complaint – you may be able to refer the matter to the Financial Ombudsman Service at:

South Quay Plaza,
183 Marsh Wall,
London E14 9SR.

Telephone: **0845 080 1800**

8.21 Compensation

British Gas Insurance Limited is covered by the Financial Services Compensation Scheme (FSCS). You may be entitled to compensation from the scheme if we cannot meet our obligations. General insurance is covered for 90% of the claim, without any upper limit. Further information about the compensation scheme is available from FSCS at www.fscs.org.uk or telephone **0207 892 7300**.

9. TimeChoice™ for Cover/Care Agreements

This is an optional service for customers who have a boiler and controls and/or central heating Agreement with an Annual Service and would like to purchase more convenient timeslots for their Annual Service and prioritised response times for repairs in the event of a breakdown.

The following are included with TimeChoice™:

- For Breakdown visits, if you have no heat or hot water and call us before 10am we will be with you on the same day.
- For Annual Service visits, we will arrive Monday to Friday within a two (2) hour appointment timeslot between 8am and 6pm. On Saturdays we will arrive within the following timeslots: 8am to 1pm; 10am to 2pm; 12 mid-day to 6pm.

Customers who purchased TimeChoice™ before 6 August 2009 can also choose an appointment in the evening Monday to Friday between 5pm and 8pm.

For more information on TimeChoice™, visit britishgas.co.uk

10. Landlord Services

Landlords who let out properties for Domestic Purposes can purchase any of our Agreements. In addition, landlords can also purchase the following additional services for their tenanted properties.

10.1 Landlords Gas Appliance Safety Inspection (LGASI)

By law, landlords must have gas appliances in properties they let checked for safety every 12 months. They should also hold a Gas Safety Record as proof.

The following are included with your LGASI:

- A one-off inspection available for gas boilers, fires and cookers (charges are per appliance); and
- A Gas Safety Record.

General Conditions and General Exclusions apply (see sections 5 to 7).

Landlords can choose to purchase LGASI as either a one-off landlord's inspection or as an annual Agreement. Landlords who purchase a LGASI and also have an Agreement with us that includes an Annual Service will receive their LGASI at the same time we carry out their Annual Service.

10.2 Landlords Electrical Inspection (LEI)

The following are included with your LEI:

- A one-off visual safety inspection of electrical wiring and electrical fixtures and PAT testing of up to five electrical appliances; and
- An Electrical Inspection Certificate.

11. Care Agreements

All Care Agreements are agreements for services provided by British Gas Services Limited.

11.1 Similar Services

We or other Centrica Group companies may introduce insurance agreements that provide similar services and additional benefits to those that are currently being provided to you under your Care Agreement(s). If you pay by Direct Debit you hereby request and confirm that at the next anniversary of your Care Agreement(s) we may arrange those insurance agreements for you and then renew them annually until you notify us otherwise. You can call us anytime on **0800 0727 513** if you would prefer to revert back to your Care Agreement(s).

Boiler and Controls, Central Heating and Gas Appliance Care/Check

11.2 Boiler and Controls Care™

The following are included in your Agreement:

- Service and repairs in the event of breakdown of a single gas boiler and controls in your Home (shown in light blue in the diagram on page 2).
- Parts and labour – as long as all the essential working parts are available and we have approved your appliance.
- Boiler replacement under the circumstances and in accordance with the terms of the 'General Conditions' (see section 6).
- First Service of your boiler in your first year and Annual Service of your boiler in subsequent years.
- Costs up to £1,000 (including VAT) we would incur to get access to your system/appliance in order to make a repair, (for example, pipes buried in walls or 'built-in' appliances) and making good. Making good damage caused by gaining necessary access means filling or plastering to make level but excludes any redecoration which will be your responsibility. We do not include the cost of getting to your appliance where your system is inaccessible due to a design fault.

The Exclusions below and the General Conditions and General Exclusions apply (see sections 5 to 7).

11.3 Central Heating Care™

The following are included in your Agreement:

- Service and repairs in the event of breakdown of a single gas boiler and controls (shown in light blue in the diagram on page 2) and wet (using water) or warm-air gas central heating system in your

Home (shown in blue on the diagram on page 2) or an electric (repairs only) and solar thermal system if we installed it. Warm air vents are covered for warm air units only.

- First Service of your boiler and central heating system in your first period of Agreement and an Annual Service of your boiler and central heating system in subsequent Periods of Agreement.
- Boiler replacement under the circumstances and in accordance with the terms of the 'General Conditions' (see section 6).
- Costs up to £1,000 (including VAT) we would incur to get access your system/appliance in order to make a repair, (for example, pipes buried in walls or 'built-in' appliances) and making good. Making good damage caused by gaining necessary access means filling or plastering to make level but excludes any redecoration which will be your responsibility. We do not include the cost of getting to your appliance where your system is inaccessible due to a design fault.
- If you have central heating care plus plumbing and drains and home electrics Agreements with us, repairs to all gas-supply pipework inside your Home, between your meter and any appliances (shown as blue dots on the diagram on page 2).

The Exclusions below and the General Conditions and General Exclusions apply (see sections 5 to 7).

11.4 Gas Appliance Care™

The following are included in your Agreement:

- Service and repairs of gas appliances e.g. fires, water heaters, wall heaters and cookers in your Home (shown in orange on the diagram on page 2). Each of the appliances included under your Agreement will be specified in your Statement.
- Parts and Labour – as long as all the essential working parts are available and we have approved your appliance.
- Annual Service of your appliances.

The Exclusions below and the General Conditions and General Exclusions apply (see section 5 to 7).

11.5 Gas Appliance Check™

The following are included in your Agreement:

- Annual Service for gas appliances e.g. boilers, fires, water heaters, wall heaters and cookers in your Home (shown in orange on the diagram on page 2). Each of the appliances included in your Annual Service will be specified in your Statement.
- This Agreement does not include any repairs. You can choose to have extra work done, but you will have to pay for the parts (if available) and labour.

The Exclusions below and the General Conditions and General Exclusions apply (see sections 5 to 7).

11.6 Boiler and Controls, Central Heating and Gas Appliance Care/Check Exclusions

The following are not included in your Agreement:

- Removing sludge or hard-water scale from your system or appliance.
- Repairing damage caused by scale, sludge or other debris if we have told you permanent repairs, improvements or a PowerFlush™ (or a similar cleaning procedure) are needed to help ensure your appliance/system works properly.
- Repairing or replacing appliance flues other than room sealed appliance flues (up to 1m in length). This does not include flue terminals that are not a part of the flue system.
- Repairing or replacing appliance flues that aren't part of your boiler.
- Repairing or replacing parts of your central heating system and controls that are specifically designed for piped or electric underfloor heating (other than warm-air systems).

11.7 Plumbing Care™

The following are included in your Agreement:

- Repairs or replacement inside your home and to fixed external pipes if supplying water from your Home in the event of leaks or mechanical failure of (shown in black on the diagram on page 2):
 - hot and cold water pipes from the mains stopcock inside your Home leading to your taps and garden taps (but not including the mains stopcock and taps themselves);
 - your cold water storage tank;
 - leaking overflow pipes;
 - standard ball valves and toilet siphon;
 - pipes that burst as a result of cold weather;
 - central heating water pipes if there is a water leak;
 - radiator valves;
 - hot water cylinders and immersion heaters; and
 - washing-machine and dishwasher hot and cold flexible pipes (as long as they are installed to the manufacturer's instructions).
- Parts and labour for fitting standard replacement parts. Standard replacement parts may differ from the original, for example, using a standard flush handle to replace a gold plated flush handle, unless an alternative is provided by you.

- Costs up to £1,000 (including VAT) we would incur to get access to your system/appliance in order to make a repair, (for example, pipes buried in walls or 'built-in' appliances) and making good. Making good damage caused by gaining necessary access means filling or plastering to make level but excludes any redecoration which will be your responsibility. We do not include the cost of getting to your appliance where your system is inaccessible due to a design fault.
- Your Plumbing Care™ Agreement includes a Maintenance Inspection to check for water leaks on your internal pipework, valves and hot water cylinder. If you have Central Heating Care™, we will provide your Maintenance Inspection at the same time as your Annual Service for your boiler and central heating system. If you do not have Central Heating Care™, your Maintenance Inspection will be provided at your request once in every two consecutive Periods of Agreement.

The Exclusions below and the General Conditions and General Exclusions apply (see sections 5 to 7).

11.8 Plumbing Care™ Exclusions

The following are not included in your Agreement:

- Repairing or replacing taps.
- Repairing or replacing washers in taps.
- Repairing or replacing the mains cold water stopcock, water softeners, shower pumps and mixer valves, combined overflow and pop up waste mechanism, mechanical pumps, water filters, radiators, swimming pools, decorative garden features, rainwater pipes and guttering, waste disposal units, macerators such as Saniflo, and electrical units for toilets.
- Repairing or replacing any steel or lead pipes.
- Temporarily frozen pipes which have not resulted in confirmed damage.

11.9 Plumbing and Drains Care™

All the benefits and terms of Plumbing Care™ plus Drains;

Drains

- Restoring flow by getting to and unblocking or repairing drainage pipes and waste pipes (Shown in grey on the diagram on page 2), for example, unblocking sinks, waste and rainwater drains. This applies to pipes within the boundary of your property but only where you have sole responsibility for the pipes (this does not include public or shared drains even if these are within the boundary of your property).
- Parts and labour are included up to £1,000 (including VAT) per repair to access your system and make repairs.

The Exclusions below and the General Conditions and General Exclusions apply (see sections 5 to 7).

11.10 Drains Exclusions

The following are not included in your Agreement:

- Repairing or replacing manholes, soakaways, septic tanks, cesspits, treatment plants and their outflow pipes.
- Regularly cleaning your drains and any de-scaling of your drains.
- Repairing or unblocking drains shared with another property or properties **that are the responsibility of your water company.**
- Repairing or unblocking drains outside the boundary of your property.
- Repairing or unblocking drains which are used for mainly commercial purposes.
- Making access to drain system points of entry (such as manhole covers) where these have been built over.
- Repairing or replacing any steel or lead pipes.
- Temporarily frozen pipes which have not resulted in confirmed damage.

11.11 Home Electrical Care™

The following are included in your Agreement:

- Repairs of electrical wiring and electrical fixtures inside your Home (shown in dark purple on the diagram on page 2) and within outbuildings as long as the outbuildings do not contain their own power supply and the wiring and fixtures have been installed correctly. This covers the fixed electrical wiring system and fuse boxes, light switches, wall sockets, light fixtures, circuit breakers and transformers.
- Parts and labour are included for fitting standard replacement parts, for example, we will replace all fittings with our nearest equivalent standard white plastic, brass or chrome effect fitting unless an alternative is provided by you.
- Outside security/doorway lighting fitted less than 10 metres above ground level.
- Rodent damage to wiring (property must not be unoccupied for a continuous period of 4 weeks or more).
- Repairs to electric door bells (excluding door entry systems), bathroom extractor fans and smoke alarms connected to the wiring of your Home.
- Repairs to your electric vehicle charging unit if installed by us.
- Repairs following breakdowns to your Solar Photovoltaic panels and system if installed by us.

- Costs up to £1,000 (including VAT) we would incur to get access to your system/appliance in order to make a repair, (for example, pipes buried in walls or 'built-in' appliances) and making good. Making good damage caused by gaining necessary access means filling or plastering to make level but excludes any redecoration which will be your responsibility. We do not include the cost of getting to your appliance where your system is inaccessible due to a design fault.
- Maintenance Inspection at your request once in every two-year continuous Period of Agreement.

The Exclusions below and the General Conditions and General Exclusions apply (see sections 5 to 7).

11.12 Home Electrical Care™ Exclusions

The following are not included in your Agreement:

- Repairing controls, pumps, detectors, timers and programmers.
- Repairing or replacing the mains supply up to the fuse box.
- Repairing the parts of the power supply between your Home and the outbuildings on your property that are outside of the buildings.
- Repairing or replacing rubber or lead wiring.
- Repair of accidental damage.
- Damage to or replacement of Solar Photovoltaic Panels and installations caused by risks normally covered under household or other insurances (see General Exclusions sections 5 to 7).

11.13 Kitchen Appliance Care™

- Maintenance and repairs, including parts and labour, of gas and electrical appliances inside your Home (shown in lilac on the diagram on page 2). The appliances included under your particular Agreement will be set out in your Statement. An appliance can only be included if it was bought in the United Kingdom and it is in good working order at the time we process your Agreement.
- The appliances that can be included under Kitchen Appliance Care™ are:
 - automatic and tub washing machines;
 - automatic washer-dryers, spin and tumble dryers and dishwashers;
 - fridges, freezers, fridge-freezers; and
 - cookers, ovens, hobs and microwave ovens (but not cooker hoods and extractors).

- Parts and labour – as long as all the essential working parts are available.
- If we cannot repair your appliance, for example, because spare parts are no longer available to carry out the repair:
 - If your Agreement relates to one appliance, we will refund the amount you have paid to us under this Agreement for the appliance we are not able to repair (up to 12 months' payments);
 - If your Agreement relates to more than one appliance, we will refund the amount you have paid to us under this Agreement for the appliance(s) we are not able to repair (up to 12 months' payments);
 - If you have paid us in advance for 12 months but the affected appliance has been part of your Agreement for less than 12 months, we will refund your 12 months' payments relating to that particular appliance as set out above.
 - For details of the refund value for each type of appliance, please call **0800 365 100**.
- Maintenance Inspection at your request of the kitchen appliances included under your Agreement once in every two-year continuous Period of Agreement.

The Exclusions below and the General Conditions and General Exclusions apply (see section 5 to 7).

11.14 Complaints

We will always aim to do our best but unfortunately there may be times when things go wrong. If you have a complaint about any part of our service or your products please telephone us on **0800 294 9650** or write to us at:

British Gas Services,
Customer Relations,
PO Box 4395,
Dunstable LU6 9LH

or email us at:
BGS.CustomerRelations@centrica.com

We will try to deal with the matter immediately but if we can't then we will keep you regularly informed about the progress of our investigation.

12. Using personal information (applicable to all Agreements)

We or our agents may use information about you to do the following:

- provide you with the services you have requested (which may include loyalty and incentive schemes we may run from time to time);

- offer you accounts, services and products from time to time from us and our partners. To help us make these offers we may use an automatic scoring system, which also uses information about you from other credit reference agencies, as well as other companies;
- help run, and contact you about improving the way we run, any accounts, services and products we have provided before, now or in the future;
- create statistics, test computer systems, analyse customer information, create profiles and create marketing opportunities (including using information about what you buy from us and how you pay for it, for example the amount of gas or electricity you use and any discounts we have offered you);
- help to prevent and detect debt, fraud or loss;
- help train our staff; and
- contact you in any way (including by post, e-mail, phone, text or multimedia messages or other forms of electronic communications (such as smart meters) or by visiting you) about products and services we and our partners are offering.

When we contact you, we may use any information we hold about you to do so. We may contact you by e-mail, phone, text message or other forms of electronic communications (such as using smart meters) or by visiting you. If we are contacting you to tell you about any offers, we will, as far as possible, do this in line with how you have told us you would prefer to receiving marketing information (your recorded marketing preferences). You can ask us not to send you any information on our offers at any time by contacting us and giving us your account details.

We may allow other people and organisations to use information we hold about you (including British Gas, Scottish Gas and Dyno Group):

- to provide services you have asked for, which may include providing information to members of your family or household, anyone acting on your behalf or other people who may be interested (such as landlords or letting agents);
- as part of the process of selling one or more of our businesses;
- to help to prevent and detect debt, fraud or loss (for example by giving this information to a credit-reference agency) which is described in more detail below;
- if you do not pay your debt, we may transfer your debt to another organisation and give them details about you and that debt;
- if we have been asked (for example by Ofgem or a lawyer) to provide information for legal or regulatory purposes;
- as part of current or future legal action;
- as part of government data-sharing initiatives; for example, those designed to help stop fuel poverty (where people can not afford to pay for heating and electricity);
- to help manage any loyalty or rewards schemes or

- if you hold an insurance policy with us, to pass information to an insurer to manage your insurance policy (including underwriting and claims, to help develop new services and to assess financial and insurance risk).

From time to time these other people and organisations may be outside the European Economic Area (EEA) and as a result we may pass your information to countries that do not have the same standards of protection for personal information as the UK.

We may use your information to help train our staff. We may also monitor and record any communications we have with you including phone conversations and e-mails, to make sure that we are providing a good service and to make sure we are meeting our legal and regulatory responsibilities.

If we suspect someone has committed fraud or stolen energy by tampering with the meter or diverting the energy supply, we will record these details on your account record and may share this information with Ofgem and other people who are interested (such as other energy suppliers, landlords and housing associations). We may use this information to make decisions about you, your character, how likely we think you are to pay for your gas or electricity (or both) and future energy services. This may include recording sensitive personal information such as criminal offences you have been accused of. Also if the gas or electricity supply to your property has previously been tampered with or if gas or electricity has been stolen, or we suspect it has been stolen, we may take this into account when we decide what products or services we can offer you and the terms and conditions we give you.

We may pass your address, property and postcode, and details of your gas appliances, flue, hot-water cylinder, system controls and electrical installations (including details of any repairs or removals), to organisations that supervise these activities including GasSafe (previously CORGI) and the ECA (Electrical Contractors Association). These organisations may pass this information to local authorities to meet building regulations. They may also use this information to contact you to inspect appliances or systems, recall faulty products and carry out audits, and for health and safety purposes. Where appropriate, we will give you or the property owner (or both) a certificate to show that your appliances meet building regulations.

We will check your details with one or more credit-reference and fraud-prevention agencies to help us make decisions about your ability to make payments and the goods and services we can offer you. Below, we have given a brief guide to how we, the credit-reference and fraud-prevention agencies will use your information. If you would like more information about this, you can find the full version online at britishgas.co.uk or phone us on **0800 048 0202** and we will send you a leaflet.

We will search at credit-reference and fraud-prevention agencies for information about you and all the people you are applying with. If you are providing information about other people on a joint

application, you must make sure they agree that we can use their information to do this. If you give us false or inaccurate information and fraud is identified, we will pass your details to credit-reference and fraud-prevention agencies.

Law enforcement agencies (such as the Police and HM Revenue and Customs) may receive and use this information.

- We and other organisations may also access and use information about you that credit-reference and fraud-prevention agencies give us to, for example:
 - check details on applications you make for credit and credit-related services;
 - check your identity;
 - prevent and detect fraud and money laundering;
 - manage credit and credit-related accounts or services;
 - recover debt;
 - check details on proposals and claims for all types of insurance; and
 - check details of employees and people applying for jobs with us.
 - When credit-reference agencies receive a search from us, they will record this on your credit file whether your application is successful or not.
 - We will send information on your account to credit reference agencies and they will record it if you have an account with us, we will give details of it and how you manage it to credit reference agencies. If you have an account and do not repay money you owe in full or on time, credit reference agencies will record this debt. They may give this information to other organisations and fraud prevention agencies to carry out similar checks, find out where you are and deal with any money you owe. The credit reference agencies keep records for six years after your account has been closed, you have paid the final debt or action has been taken against you to recover the debt.
 - We and other organizations may access and use, from other countries, information recorded by fraud-prevention agencies.
 - If you want to see what information credit-reference and fraud-prevention agencies hold about you, you can contact the following agencies currently working in the UK. The information they hold may not be the same, so it is worth contacting them all. They will charge you a small fee.
- Call Credit**
Consumer Services Team,
PO Box 491,
Leeds LS3 1WZ.
Phone: 0870 060 1414
Website: www.callcredit.co.uk

Equifax plc
Credit File Advice Centre,
PO Box 1140,
Bradford BD1 5US.
Phone: 0870 010 0583
Website: www.myequifax.co.uk

Experian
Consumer Help Service,
PO Box 8000,
Nottingham NG80 7WF.
Phone: 0870 2441 6212
Website: www.experian.co.uk

If you give us information on behalf of someone else, you confirm you have given them the information set out in this document, and that they have given permission for us to use their personal information in the way we have described in this section. If you give us sensitive information about yourself or other people (such as health details or details of any criminal convictions of members of your household), you agree (and confirm that the person the information is about has agreed) that we can use this information in the way set out in this document.

You are entitled to have a copy of the information we hold on you and to have any inaccurate information corrected. We may charge a small fee for providing a copy of any information we hold about you. For more information about this please contact our Privacy Unit at

Data Protection Co-ordinator,
Newbridge House,
Leeds City Office Park,
Kidacre Street,
Holbeck,
Leeds LS11 5BD

or you can email: CentricaDataProtection@Centrica.com

13. Other Products and Services

13.1 Powerflush™

You can purchase Powerflush™ to remove sludge and other waste from your central heating system. Once you have purchased Powerflush™ from us, there will be no charge for any future PowerFlush™ work that may be needed, as long as you keep a continuous HomeCare® Agreement (that includes boilers) at that property.

13.2 System filters and scale reducers

You can purchase system filters and scale reducers. Once we have installed them, there will be no charge for any future system filter work that may be needed, as long as you keep a continuous

HomeCare® Agreement at that property. As part of any Annual Service, if necessary we will also clean the filter on any system filter you have had installed, whether or not we have installed it.

13.3 Condensate pipe kits

You can purchase Trace Heater kits/frost protection to help protect your condensate pipe from freezing over. Once we have installed them, there will be no charge for any future Trace Heater kits/frost protection that may be needed, as long as you keep a continuous HomeCare® Agreement at that property.

Separate terms and conditions apply to the products and services in this section 13.

14. Frequently asked questions

Q My boiler, appliance or system is old, does my HomeCare® Agreement still cover me?

A There is no age limit on your boiler, appliance or system and it does not matter who installed it, as long as all the essential working parts are available. If some parts are not available we will let you know.

Q Am I covered for replacement taps?

A Tap repairs are included in your Agreement but not replacement taps or replacing ceramic discs in taps. To find out how to tell if your taps contain rubber washers or ceramic discs go to britishgas.co.uk/washers or you can call us on **0800 365 100**, or write to Customer Services Workflow Team, Murdoch House, Bothwell Road, Uddingston G71 7TW. If you need a replacement tap, we can offer to supply and fit one from our range of taps or fit a tap that you provide at a discounted cost on both the part and fitting.

Q Why do your engineers recommend changes to my system?

A Our engineers are highly qualified and up to date with the latest technology and legislation. If they identify a possible change or improvement to your system they will only recommend this if, in their expert opinion, it is necessary.

Q What do 'Upgrades to my system' mean?

A Upgrades are changes to your system which will improve its efficiency or safety. Examples of upgrades are replacing working radiators with improved models, replacing standard radiator valves with thermostatic radiator valves, Powerflush™ and System filters. Upgrades are not included in your Agreement.

Q I need a new boiler, do I receive any benefits by being a HomeCare® customer?

A Yes, as a HomeCare® customer with a boiler or central heating Agreement you are entitled to a special offer on installing a new boiler, if British Gas install it.

Q My pipes seem to be frozen, can you offer any advice to fix these?

A You can usually decrease the thaw time by applying gentle heat to the frozen area. Wrapping hot towels around the pipework can be effective, or adding an extra non direct heat source to the area containing the frozen pipes. Be aware that applying too much direct heat, such as a blow torch or a naked flame can cause damage to the pipework or surrounding area, and could create a fire risk; therefore this method of thawing must be avoided. Care should also be taken where electrical appliances (fan heaters etc) are used to heat the area, do not use where there is a risk of flooding or contact with water.

Service Expectations

Q How will I know what the engineer has done at my First Service, Annual Service or breakdown?

A Our engineer will fill in a checklist which they will leave with you as a record of what has been checked or repaired. The engineer will explain this to you and will answer any questions you may have.

Q My new Agreement includes a First Service, when will this take place?

A We aim to carry out this service within 42 days from the beginning of your Agreement. However as we give priority to breakdowns, on occasions it can be later if there is a lot of demand for our services, especially in colder periods.

Q I think my Annual Service is due but I haven't heard from you?

A On or around the anniversary date of your last Annual Service we will contact you in writing, email or by telephone to arrange a suitable appointment. On occasions this may happen earlier or later than you expect, if there has been or we expect there to be, a lot of demand for breakdown repairs.

Q My boiler is broken and I have no heating or hot water. How quickly will the engineer get to me?

A If you have no heating or hot water and you let us know before 1pm we aim to be with you the same day. If you call after this time we aim to be with you within 24 hours. If we cannot get to you in these timescales we will do our utmost to be with you as soon as possible thereafter.

Q. I have a problem with my boiler, but I still have heating. How quickly will the engineer get to me?

A This will depend on a number of factors but we will normally aim to be with you within 3 to 5 days from your call, on a day that suits you.

Q Why is it more difficult for you to visit me quickly when it is cold?

A Demand for repairs goes up sharply when it is colder and we can't always accurately predict when this will be. This means we can't always get to everyone as quickly as we would like. In these circumstances we prioritise customers based on the severity of their problem and how vulnerable they may be to being without heating or hot water.

Q Why doesn't the engineer have the necessary part to fix my problem?

A Our engineers carry a van stock of the most commonly used parts in your area. Unfortunately, with the huge range of boilers and parts available it is not possible to carry all the parts that might be required. If a part is not available on the van, we aim to get what is required to the engineer as soon as possible and in most cases for the next day.

Q Can my Annual Service be done at the same time as a repair and vice versa?

A Yes, if you have a problem which you want us to look at during your Annual Service let us know when you arrange your appointment so that we can ensure the engineer has enough time to do both. If you need a repair and your Annual Service is due we will ask if we can do both in the same visit. Many of our customers find this is more convenient for them.

Miscellaneous

Q Why has my price changed from last year?

A In the first year of your Agreement we have limited information about your boiler, system and usage so your price is based on our average costs. In subsequent years we have much more detailed and accurate information about your boiler and system which means the price we charge is tailored to you. This means we can be fairer in our pricing, by charging less for customers who rarely have a breakdown, have a smaller property or a boiler which is cheaper to maintain and more for customers who have frequent breakdowns and boilers which are costly to maintain.

Q In what circumstances would you suspend or cancel my Agreement due to a health and safety risk?

A If we encounter hazardous materials, infestations or receive physical or verbal abuse we would suspend or cancel your Agreement until the health and safety risk is resolved to our satisfaction.



Need an engineer?

Call us on **0800 294 9650**



Contact us

To switch your gas and electricity call
0800 048 1644

For all Agreement Enquiries call free
0800 365 100

If you're moving house call free
0800 365 100

For great value on a new energy-efficient boiler, call
0800 009 4405



If you would like this booklet in an alternative format such as large print, Braille or audio cassette, please call **0800 365 100**.



If you are hard of hearing or speech impaired and use a textphone, please call **18001 0845 070 0178**.

British Gas Insurance Limited and British Gas Services Limited are authorised and regulated by the Financial Services Authority (FSA). FSA registration numbers are 490565 and 490568 respectively, these can be checked on the FSA register at www.fsa.gov.uk/register or by calling the FSA on 0845 6061234. Registered Office for British Gas group companies: Millstream, Maidenhead Road, Windsor, Berkshire SL4 5GD. Both companies are registered in England and their company numbers are 6608316 and 3141243 respectively.